

SUBJECT-BASIC ELECTRONICS ENGINEERING

TOPIC-PROBLEM AND SOLUTIONS

Prepared by Mr. Bikash Meher

Assistant Professor

Department-EE

Topic includes

- **Diode**
- **BJT and Biasing**
- **FET and MOSFET**
- **OP-AMP**

Semiconductor Diode

Problems and Solutions

Problem 1. An a.c. voltage of peak value 20 V is connected in series with a silicon diode and load resistance of 500 Ω . If the forward resistance of diode is 10 Ω , find :
 (i) peak current through diode (ii) peak output voltage
 What will be these values if the diode is assumed to be ideal ?

Solution :

Peak input voltage = 20 V

Forward resistance, $r_f = 10 \Omega$

Load resistance, $R_L = 500 \Omega$

Potential barrier voltage, $V_0 = 0.7 \text{ V}$

The diode will conduct during the positive half-cycles of a.c. input voltage only.

The equivalent circuit is shown in Fig.1(ii)

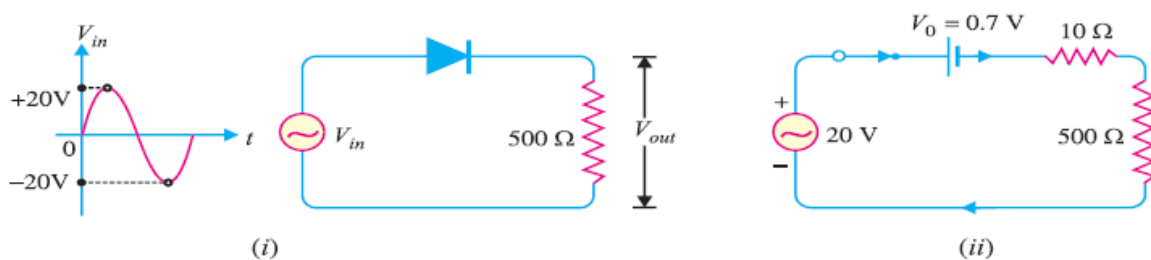

Fig. 1

(i) The peak current through the diode will occur at the instant when the input voltage reaches positive peak i.e. $V_{in} = V_F = 20 \text{ V}$.

$$\therefore V_F = V_0 + (I_f)_{peak} [r_f + R_L] \quad \dots(i)$$

$$\text{or} \quad (I_f)_{peak} = \frac{V_F - V_0}{r_f + R_L} = \frac{20 - 0.7}{10 + 500} = \frac{19.3}{510} \text{ A} = \mathbf{37.8 \text{ mA}}$$

(ii) Peak output voltage :

$$\text{Peak output voltage} = (I_f)_{peak} \times R_L = 37.8 \text{ mA} \times 500 \Omega = \mathbf{18.9 \text{ V}}$$

Ideal Diode Case:

For an ideal diode, put $V_0 = 0$ and $r_f = 0$ in equation (i).

$$V_F = (I_f)_{peak} \times R_L$$

$$\text{or} \quad (I_f)_{peak} = \frac{V_F}{R_L} = \frac{20 \text{ V}}{500 \Omega} = \mathbf{40 \text{ mA}}$$

$$\text{Peak output voltage} = (I_f)_{peak} \times R_L = 40 \text{ mA} \times 500 \Omega = \mathbf{20 \text{ V}}$$

Problem 2. Find the current through the diode in the circuit shown in Fig. 2 (i). Assume the diode to be ideal.

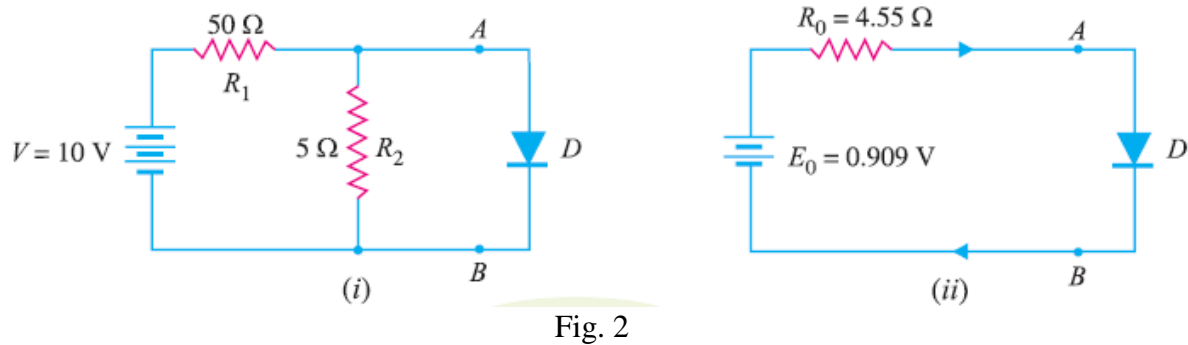

Fig. 2

Solution :

We shall use Thevenin's theorem to find current in the diode. Referring to Fig. 2(i),

$$\begin{aligned}
 E_0 &= \text{Thevenin's voltage} \\
 &= \text{Open circuited voltage across } AB \text{ with diode removed} \\
 &= \frac{R_2}{R_1 + R_2} \times V = \frac{5}{50 + 5} \times 10 = 0.909 \text{ V} \\
 R_0 &= \text{Thevenin's resistance} \\
 &= \text{Resistance at terminals } AB \text{ with diode removed and battery} \\
 &\quad \text{replaced by a short circuit} \\
 &= \frac{R_1 R_2}{R_1 + R_2} = \frac{50 \times 5}{50 + 5} = 4.55 \Omega
 \end{aligned}$$

Fig. 2 (ii) shows Thevenin's equivalent circuit. Since the diode is ideal, it has zero resistance

$$\therefore \text{Current through diode} = \frac{E_0}{R_0} = \frac{0.909}{4.55} = 0.2 \text{ A} = \mathbf{200 \text{ mA}}$$

Problem 3. Calculate the current through 48Ω resistor in the circuit shown in Fig. 3 (i). Assume the diodes to be of silicon and forward resistance of each diode is 1Ω .

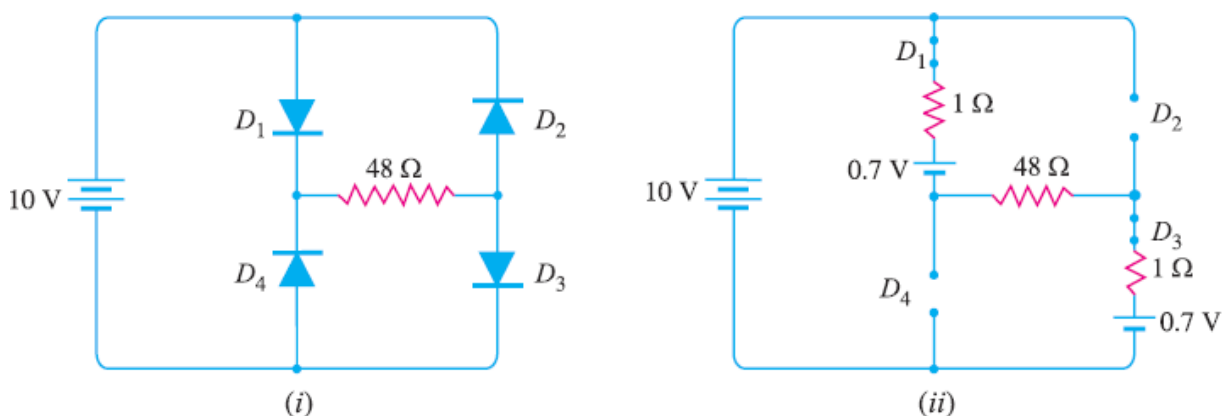

Fig. 3

Solution :

Diodes D_1 and D_3 are forward biased while diodes D_2 and D_4 are reverse biased. We can, therefore, consider the branches containing diodes D_2 and D_4 as “open”.

Replacing diodes D_1 and D_3 by their equivalent circuits and making the branches containing diodes D_2 and D_4 open, we get the circuit shown in Fig. 3 (ii). As we know for a silicon diode, the barrier voltage is 0.7 V.

$$\text{Net circuit voltage} = 10 - 0.7 - 0.7 = 8.6 \text{ V}$$

$$\text{Total circuit resistance} = 1 + 48 + 1 = 50 \Omega$$

$$\therefore \text{Circuit current} = 8.6/50 = 0.172 \text{ A} = \mathbf{172 \text{ mA}}$$

Problem 4. Determine the current I in the circuit shown in Fig. 4 (i). Assume the diodes to be of silicon and forward resistance of diodes to be zero.

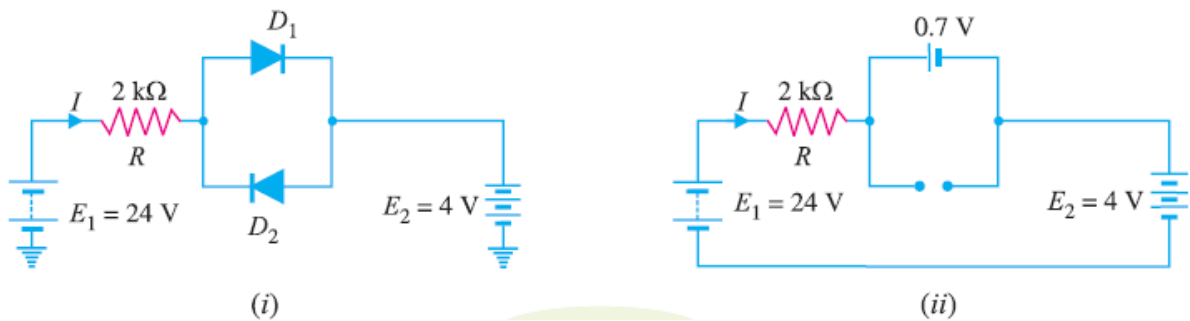

Fig. 4

Solution :

The conditions of the problem suggest that diode D_1 is forward biased and diode D_2 is reverse biased. We can, therefore, consider the branch containing diode D_2 as open as shown in Fig. 4 (ii).

Further, diode D_1 can be replaced by its simplified equivalent circuit.

$$I = \frac{E_1 - E_2 - V_0}{R} = \frac{24 - 4 - 0.7}{2 \text{ k}\Omega} = \frac{19.3 \text{ V}}{2 \text{ k}\Omega} = \mathbf{9.65 \text{ mA}}$$

Problem 5. Find the voltage V_A in the circuit shown in Fig. 5 (i). Use simplified model.



Fig. 5

Solution :

It appears that when the applied voltage is switched on, both the diodes will turn “on”. But that is not so. When voltage is applied, germanium diode ($V_0 = 0.3\text{ V}$) will turn on first and a level of 0.3 V is maintained across the parallel circuit.

The silicon diode never gets the opportunity to have 0.7 V across it and, therefore, remains in open-circuit state as shown in Fig.5(ii).

$$V_A = 20 - 0.3 = 19.7\text{ V}$$

$$V_D = \frac{2\text{ V}}{1\text{ k}\Omega + 4\text{ k}\Omega} \times 1\text{ k}\Omega = 0.4\text{ V}$$

Problem 6. Find V_Q and I_D in the network shown in Fig. 6(i). Use simplified model.

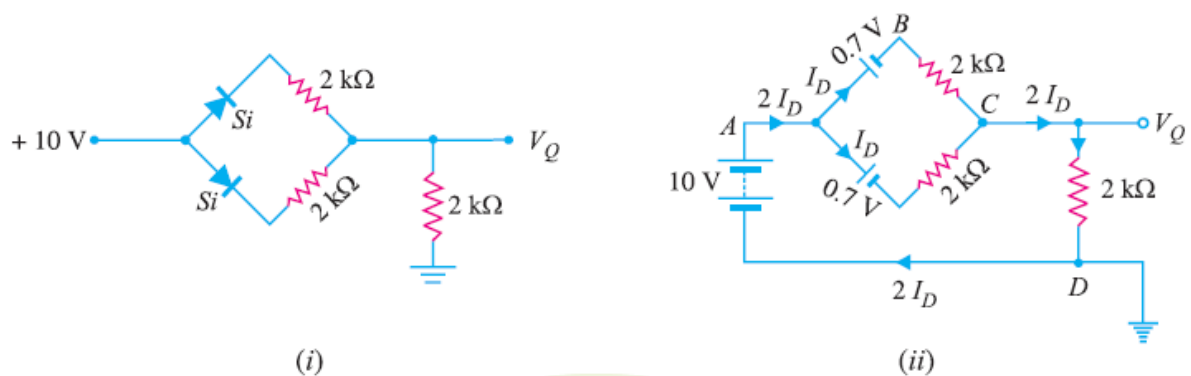

Fig. 6

Solution :

Replace the diodes by their simplified models. The resulting circuit will be as shown in Fig. 6 (ii).

By symmetry, current in each branch is I_D so that current in branch CD is $2I_D$. Applying Kirchhoff's voltage law to the closed circuit ABCDA, we have,

$$-0.7 - I_D \times 2 - 2I_D \times 2 + 10 = 0 \quad (I_D \text{ in mA})$$

or $6I_D = 9.3$

$$\therefore I_D = \frac{9.3}{6} = 1.55 \text{ mA}$$

Also $V_Q = (2I_D) \times 2 \text{ k}\Omega = (2 \times 1.55 \text{ mA}) \times 2 \text{ k}\Omega = 6.2 \text{ V}$

Problem 7. Determine current through each diode in the circuit shown in Fig. 7 (i). Use simplified model. Assume diodes to be similar.

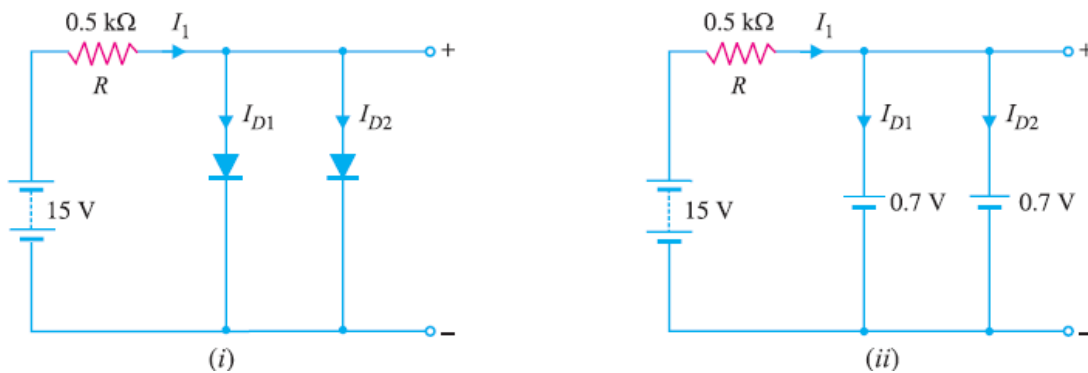

Fig. 7

Solution :

The applied voltage forward biases each diode so that they conduct current in the same direction. Fig. 7 (ii) shows the equivalent circuit using simplified model. Referring to Fig. 7 (ii),

$$I_1 = \frac{\text{Voltage across } R}{R} = \frac{15 - 0.7}{0.5 \text{ k}\Omega} = 28.6 \text{ mA}$$

$$\text{Since the diodes are similar, } I_{D1} = I_{D2} = \frac{I_1}{2} = \frac{28.6}{2} = 14.3 \text{ mA}$$

Problem 8. Determine the currents I_1 , I_2 and I_3 for the network shown in Fig. 8(i). Use simplified model for the diodes.

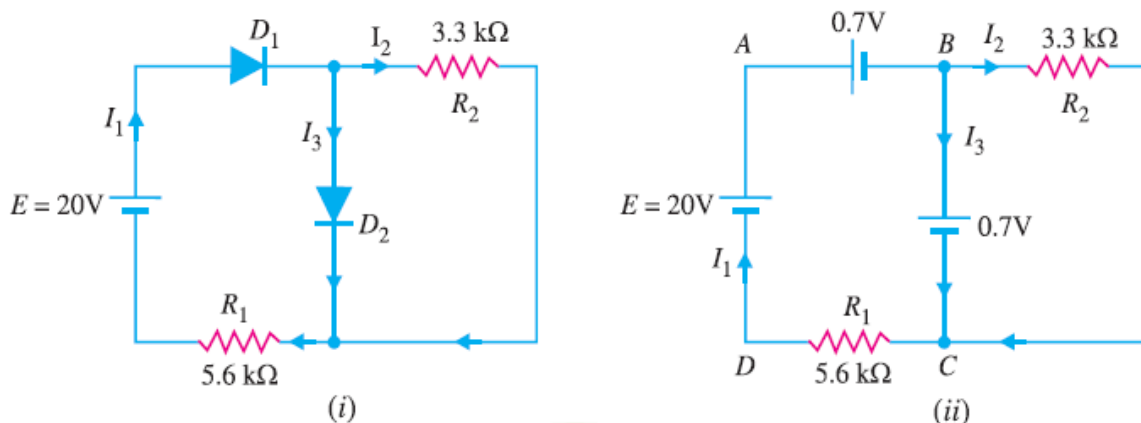

Fig. 8

Solution :

As we can see in Fig. 8 (i) both diodes D_1 and D_2 are forward biased. Using simplified model for the diodes, the circuit shown in Fig. 8 (i) becomes the one shown in Fig. 8 (ii).

The voltage across R_2 ($= 3.3 \text{ k}\Omega$) is 0.7V .

$$\therefore I_2 = \frac{0.7 \text{ V}}{3.3 \text{ k}\Omega} = \mathbf{0.212 \text{ mA}}$$

Applying Kirchhoff's voltage law to loop ABCDA in Fig. 8 (ii), we have,

$$-0.7 - 0.7 - I_1 R_1 + 20 = 0$$

$$\therefore I_1 = \frac{20 - 0.7 - 0.7}{R_1} = \frac{18.6 \text{ V}}{5.6 \text{ k}\Omega} = \mathbf{3.32 \text{ mA}}$$

$$\text{Now } I_1 = I_2 + I_3$$

$$\therefore I_3 = I_1 - I_2 = 3.32 - 0.212 = \mathbf{3.108 \text{ mA}}$$

Problem 9. Determine if the diode (ideal) in Fig. 9 (i) is forward biased or reverse biased.

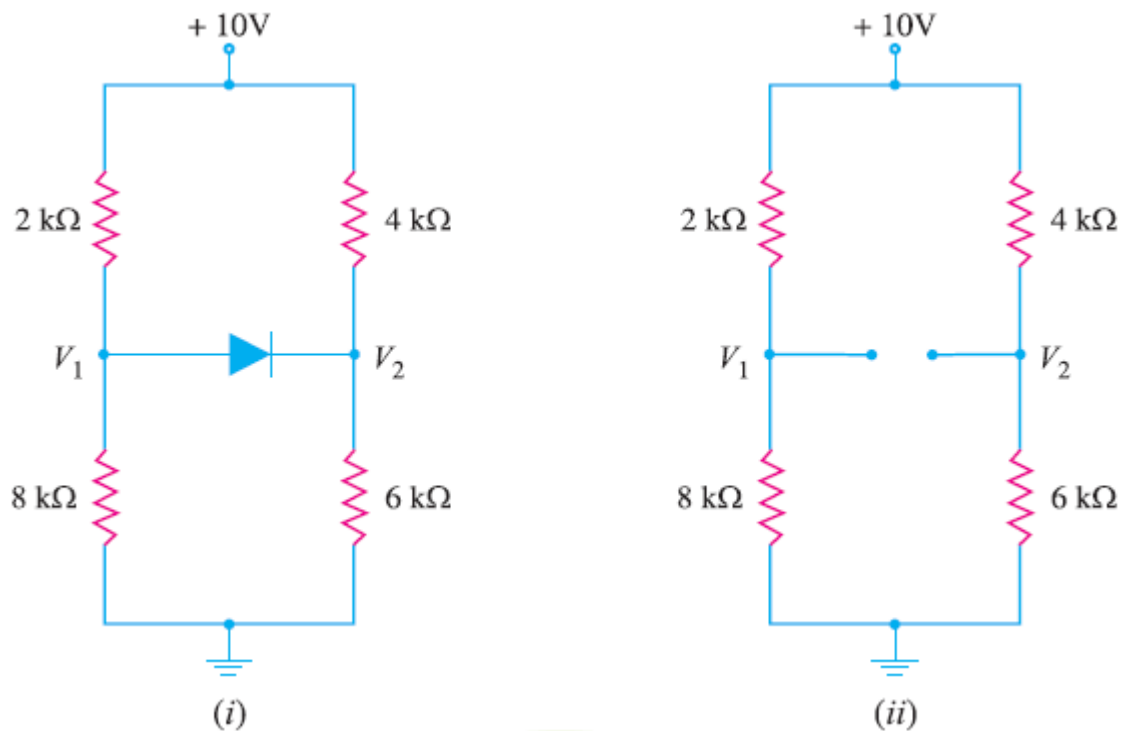

Fig. 9

Solution :

Let us assume that diode in Fig.9 (i) is OFF i.e. it is reverse biased.

The circuit then becomes as shown in Fig. 9(ii). Referring to Fig. 9 (ii), we have,

$$V_1 = \frac{10 \text{ V}}{2 \text{ k}\Omega + 8 \text{ k}\Omega} \times 8 \text{ k}\Omega = 8 \text{ V}$$

$$V_2 = \frac{10 \text{ V}}{4 \text{ k}\Omega + 6 \text{ k}\Omega} \times 6 \text{ k}\Omega = 6 \text{ V}$$

$$\therefore \text{Voltage across diode} = V_1 - V_2 = 8 - 6 = 2 \text{ V}$$

Now $V_1 - V_2 = 2 \text{ V}$ is enough voltage to make the diode forward biased. Therefore, our initial assumption was wrong, and diode is forward biased.

Problem 10. Determine the state of diode for the circuit shown in Fig. 10 (i) and find I_D and V_D . Assume simplified model for the diode.

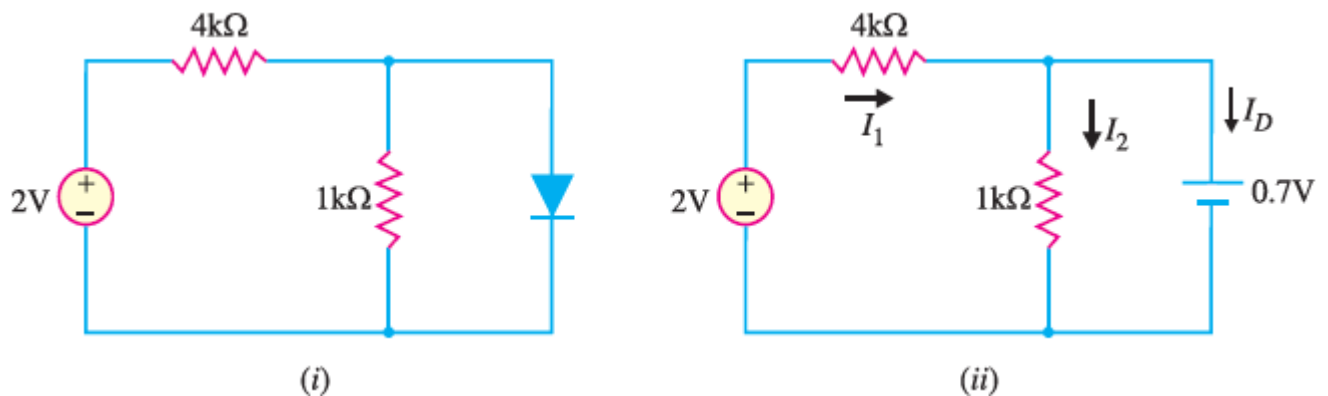

Fig. 10

Solution :

Let us assume that the diode is ON. Therefore, we can replace the diode with a 0.7V battery as shown in Fig. 10 (ii). Referring to Fig.10 (ii), we have,

$$I_1 = \frac{(2 - 0.7) \text{ V}}{4 \text{ k}\Omega} = \frac{1.3 \text{ V}}{4 \text{ k}\Omega} = 0.325 \text{ mA}$$

$$I_2 = \frac{0.7 \text{ V}}{1 \text{ k}\Omega} = 0.7 \text{ mA}$$

$$\text{Now } I_D = I_1 - I_2 = 0.325 - 0.7 = -0.375 \text{ mA}$$

Since the diode current is negative, the diode must be OFF and the true value of diode current is $I_D = 0 \text{ mA}$. Hence our initial assumption was wrong.

In order to analyse the circuit properly, we should replace the diode in Fig. 10 (i) with an open circuit as shown in Fig.10(iii).

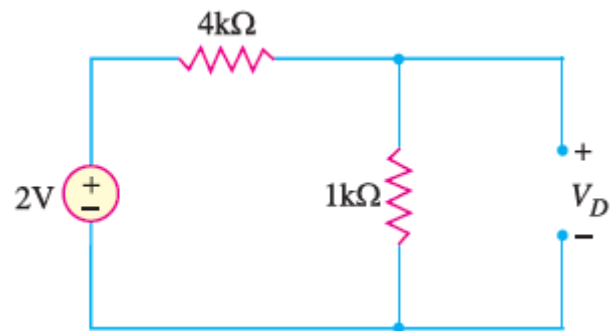

Fig.10 (iii)

The voltage V_D across the diode is :

$$V_D = \frac{2 \text{ V}}{1 \text{ k}\Omega + 4 \text{ k}\Omega} \times 1 \text{ k}\Omega = 0.4 \text{ V}$$

We know that 0.7V is required to turn ON the diode. Since V_D is only 0.4V, the answer confirms that the diode is OFF.

Bipolar Junction Transistor Problems and Solutions

Equations

$$I_E = I_C + I_B,$$

$$\alpha_{dc} = \frac{I_C}{I_E},$$

$$\beta_{dc} = \frac{I_C}{I_B},$$

$$I_C = \beta I_B,$$

$$I_C = I_{C_{\text{majority}}} + I_{C_{\text{minority}}},$$

$$\alpha_{ac} = \left. \frac{\Delta I_C}{\Delta I_E} \right|_{V_{CB}=\text{constant}},$$

$$\beta_{ac} = \left. \frac{\Delta I_C}{\Delta I_B} \right|_{V_{CE}=\text{constant}},$$

$$I_E = (\beta + 1)I_B,$$

$$V_{BE} \cong 0.7 \text{ V}$$

$$I_{CEO} = \left. \frac{I_{CBO}}{1 - \alpha} \right|_{I_B=0 \mu\text{A}}$$

$$\alpha = \frac{\beta}{\beta + 1}$$

$$P_{C_{\text{max}}} = V_{CE} I_C$$

Q1. A common base transistor amplifier has an input resistance of 20Ω and output resistance of $100 \text{ k}\Omega$. The collector load is $1 \text{ k}\Omega$. If a signal of 500 mV is applied between emitter and base, find the voltage amplification. Assume α_{ac} to be nearly one.

Solution :

Fig.1 shows the conditions of the problem. Here the output resistance is very high as compared to input resistance, since the input junction (base to emitter) of the transistor is forward biased while the output junction (base to collector) is reverse biased.

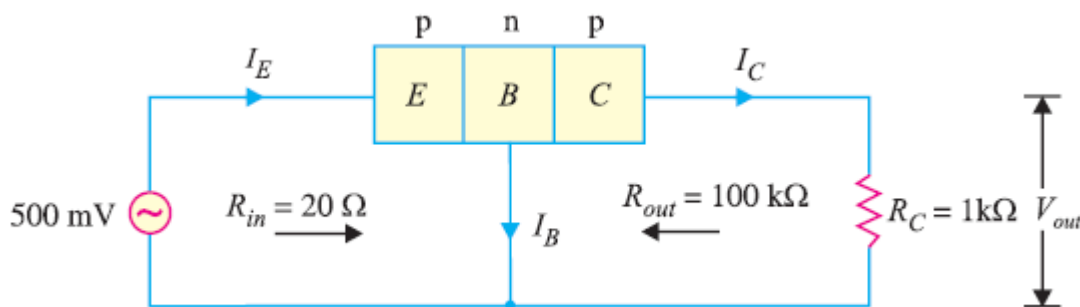

Fig. 1

Input current, $I_E = \frac{\text{Signal}}{R_{in}} = \frac{500 \text{ mV}}{20 \Omega} = 25 \text{ mA}$. Since α_{ac} is nearly 1, output current, $I_C = I_E = 25 \text{ mA}$.

Output voltage, $V_{out} = I_C R_C = 25 \text{ mA} \times 1 \text{ k}\Omega = 25 \text{ V}$

\therefore Voltage amplification, $A_v = \frac{V_{out}}{\text{signal}} = \frac{25 \text{ V}}{500 \text{ mV}} = 50$

Q2. In a common base connection, $I_E = 1 \text{ mA}$, $I_C = 0.95 \text{ mA}$. Calculate the value of I_B .

Solution:

Using the relation, $I_E = I_B + I_C$
 $1 = I_B + 0.95$
 $I_B = 1 - 0.95 = 0.05 \text{ mA}$

Q3. Find the value of β if (i) $\alpha = 0.9$ (ii) $\alpha = 0.98$ (iii) $\alpha = 0.99$.

Solution :

(i) $\alpha = 0.9$

$$\beta = \frac{\alpha}{1 - \alpha} = \frac{0.9}{1 - 0.9} = 9$$

(ii) $\alpha = 0.98$

$$\beta = \frac{\alpha}{1 - \alpha} = \frac{0.98}{1 - 0.98} = 49$$

(iii) $\alpha = 0.99$

$$\beta = \frac{\alpha}{1 - \alpha} = \frac{0.99}{1 - 0.99} = 99$$

Q4. Calculate I_E in a transistor for which $\beta = 50$ and $I_B = 20 \mu\text{A}$.

Solution :

Here $\beta = 50$, $I_B = 20 \mu\text{A} = 0.02 \text{ mA}$

Now $\beta = \frac{I_C}{I_B}$

$\therefore I_C = \beta I_B = 50 \times 0.02 = 1 \text{ mA}$

Using the relation, $I_E = I_B + I_C = 0.02 + 1 = 1.02 \text{ mA}$

Q5. Find the α rating of the transistor shown in Fig. 2. Hence determine the value of I_C using both α and β rating of the transistor.

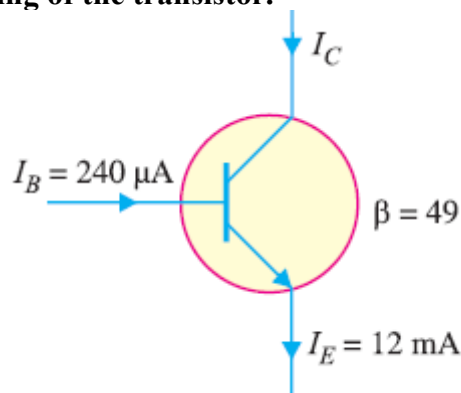

Fig. 2

Solution :

$$\alpha = \frac{\beta}{1 + \beta} = \frac{49}{1 + 49} = 0.98$$

The value of I_C can be found by using either α or β rating as under :

$$I_C = \alpha I_E = 0.98 (12 \text{ mA}) = 11.76 \text{ mA}$$

Also $I_C = \beta I_B = 49 (240 \mu\text{A}) = 11.76 \text{ mA}$

Q6. The collector leakage current in a transistor is $300 \mu\text{A}$ in CE arrangement. If now the transistor is connected in CB arrangement, what will be the leakage current? Given that $\beta = 120$.

Solution :

$$I_{CEO} = 300 \mu\text{A}$$

$$\beta = 120 ; \alpha = \frac{\beta}{\beta + 1} = \frac{120}{120 + 1} = 0.992$$

Now, $I_{CEO} = \frac{I_{CBO}}{1 - \alpha}$

$$\therefore I_{CBO} = (1 - \alpha) I_{CEO} = (1 - 0.992) \times 300 = 2.4 \mu\text{A}$$

Note that leakage current in CE arrangement (i.e. I_{CEO}) is much more than in CB arrangement (i.e. I_{CBO}).

Q7. For a certain transistor, $I_B = 20 \mu\text{A}$; $I_C = 2 \text{ mA}$ and $\beta = 80$. Calculate I_{CBO} .

Solution :

$$I_C = \beta I_B + I_{CEO}$$

or $2 = 80 \times 0.02 + I_{CEO}$

$$\therefore I_{CEO} = 2 - 80 \times 0.02 = 0.4 \text{ mA}$$

Now $\alpha = \frac{\beta}{\beta + 1} = \frac{80}{80 + 1} = 0.988$

$$\therefore I_{CBO} = (1 - \alpha) I_{CEO} = (1 - 0.988) \times 0.4 = 0.0048 \text{ mA}$$

Q8. Using diagrams, explain the correctness of the relation $I_{CEO} = (\beta + 1)I_{CBO}$.

Solution :

The leakage current I_{CBO} is the current that flows through the base-collector junction when emitter is open as shown in Fig. 3.

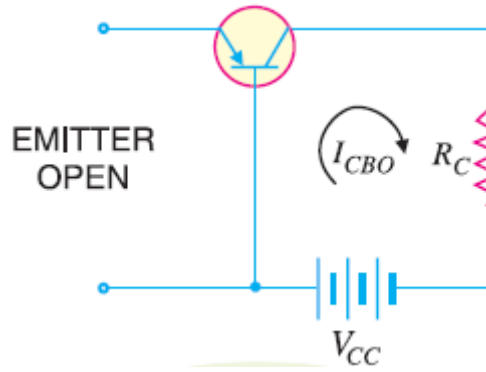

Fig. 3

When the transistor is in CE arrangement, the base current (i.e. I_{CBO}) is multiplied by β in the collector as shown in Fig. 4.

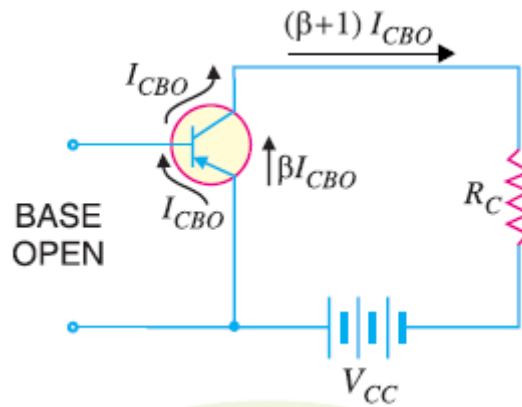

Fig. 4

$$\therefore I_{CEO} = I_{CBO} + \beta I_{CBO} = (\beta + 1) I_{CBO}$$

Q9. In a transistor, $I_B = 68 \mu\text{A}$, $I_E = 30 \text{ mA}$ and $\beta = 440$. Determine the α rating of the transistor. Then determine the value of I_C using both the α rating and β rating of the transistor.

Solution :

$$\alpha = \frac{\beta}{\beta + 1} = \frac{440}{440 + 1} = 0.9977$$

$$I_C = \alpha I_E = (0.9977) (30 \text{ mA}) = 29.93 \text{ mA}$$

Also

$$I_C = \beta I_B = (440) (68 \mu\text{A}) = 29.93 \text{ mA}$$

Q10. For the circuit shown in Fig. 5 , draw the d.c. load line.

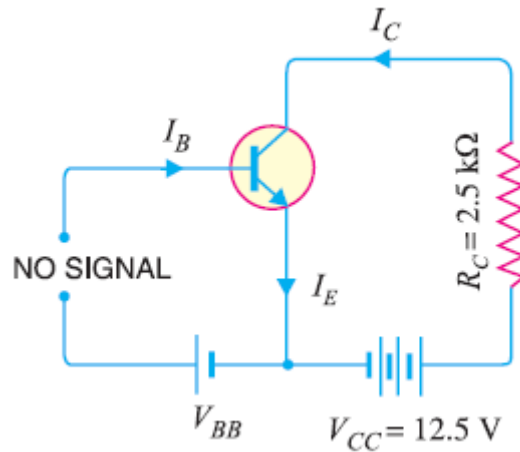

Fig. 5

Solution :

The collector-emitter voltage V_{CE} is given by ;

$$V_{CE} = V_{CC} - I_C R_C$$

When $I_C = 0$, then,

$$V_{CE} = V_{CC} = 12.5 \text{ V}$$

This locates the point B of the load line on the collector-emitter voltage axis.

When $V_{CE} = 0$, then,

$$I_C = V_{CC}/R_C = 12.5 \text{ V}/2.5 \text{ k}\Omega = 5 \text{ mA}$$

This locates the point A of the load line on the collector current axis. By joining these two points, we get the d.c. load line AB as shown in Fig. 6.

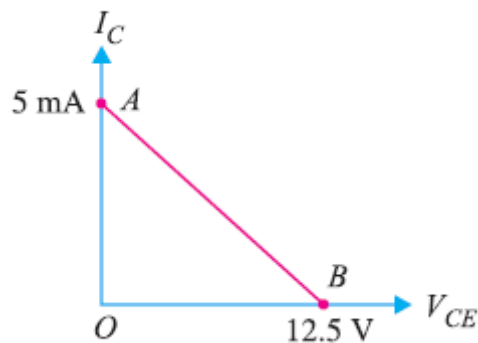

Fig.6

BJT Biasing

Problems and Solutions

Problem 1: For the fixed bias circuit of Fig. 1, determine:

(a) I_{B_Q} , (b) I_{C_Q} , (c) V_{CE_Q} , (d) V_C , (e) V_B , (f) V_E .

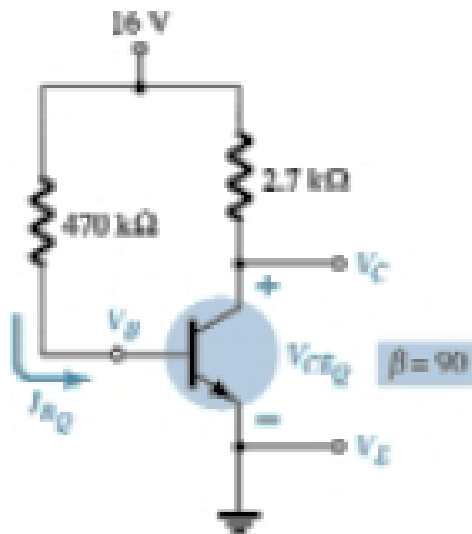

Fig. 1

Solution:

$$(a) I_{B_Q} = \frac{V_{CC} - V_{BE}}{R_B} = \frac{16\text{ V} - 0.7\text{ V}}{470\text{ k}\Omega} = 32.35\text{ }\mu\text{A}$$

$$(b) I_{C_Q} = \beta I_{B_Q} = (90)(32.35\text{ }\mu\text{A}) = 2.93\text{ mA}$$

$$(c) V_{CE_Q} = V_{CC} - I_{C_Q} R_C = 16\text{ V} - (2.93\text{ mA})(2.7\text{ K}\Omega) = 8.09\text{ V}$$

$$(d) V_C = V_{CE_Q} = 8.04\text{ V}$$

$$(e) V_B = V_{BE} = 0.7\text{ V}$$

$$(f) V_E = 0\text{ V}$$

Problem 2: Determine the I_C , V_{CC} , β , R_B for the Fig. 2.

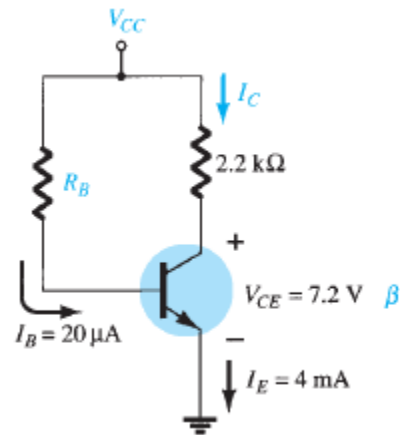

Fig. 2.

Solution:

$$I_C = I_E - I_B = 4\text{mA} - 20\mu\text{A} = 3.98\text{mA} \cong 4\text{mA}$$

$$V_{CC} = V_{CE} + I_C R_C = 7.2\text{V} + (3.98\text{mA})(2.2\text{k}\Omega) = 15.96\text{V}$$

$$\beta = \frac{I_C}{I_B} = \frac{3.98\text{mA}}{20\mu\text{A}} = 199$$

$$R_B = \frac{V_{R_B}}{I_B} = \frac{V_{CC} - V_{BE}}{I_B} = \frac{15.96\text{V} - 0.7\text{V}}{20\mu\text{A}} = 763\text{k}\Omega$$

Problem 4: Determine the dc bias voltage V_{CE} and the current I_C for the voltage-divider configuration of Fig. 3.

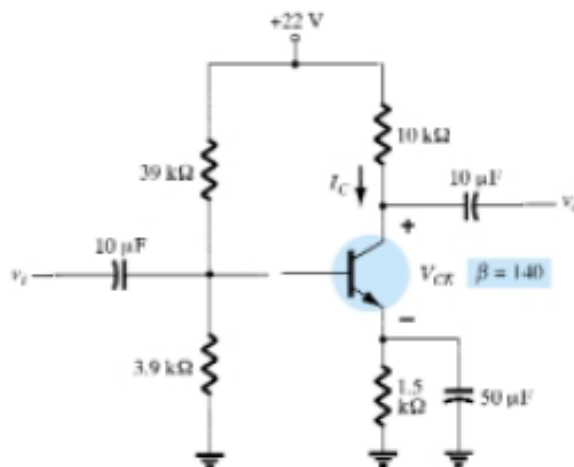

Fig. 3

Solution:

$$\begin{aligned}R_{Th} &= R_1 \parallel R_2 \\ &= \frac{(39 \text{ k}\Omega)(3.9 \text{ k}\Omega)}{39 \text{ k}\Omega + 3.9 \text{ k}\Omega} = 3.55 \text{ k}\Omega\end{aligned}$$

$$\begin{aligned}E_{Th} &= \frac{R_2 V_{CC}}{R_1 + R_2} \\ &= \frac{(3.9 \text{ k}\Omega)(22 \text{ V})}{39 \text{ k}\Omega + 3.9 \text{ k}\Omega} = 2 \text{ V}\end{aligned}$$

$$\begin{aligned}I_B &= \frac{E_{Th} - V_{BE}}{R_{Th} + (\beta + 1)R_E} \\ &= \frac{2 \text{ V} - 0.7 \text{ V}}{3.55 \text{ k}\Omega + (141)(1.5 \text{ k}\Omega)} = \frac{1.3 \text{ V}}{3.55 \text{ k}\Omega + 211.5 \text{ k}\Omega} \\ &= 6.05 \mu\text{A}\end{aligned}$$

$$\begin{aligned}I_C &= \beta I_B \\ &= (140)(6.05 \mu\text{A}) \\ &= 0.85 \text{ mA}\end{aligned}$$

$$\begin{aligned}V_{CE} &= V_{CC} - I_C(R_C + R_E) \\ &= 22 \text{ V} - (0.85 \text{ mA})(10 \text{ k}\Omega + 1.5 \text{ k}\Omega) \\ &= 22 \text{ V} - 9.78 \text{ V} \\ &= 12.22 \text{ V}\end{aligned}$$

Problem 4: Determine the following voltage divider bias configuration of Fig. 4, using approximate approach if the condition satisfied for the condition of approximate analysis.

(a) I_C , (b) V_{CE} , (c) I_B , (d) V_E , (e) V_B .

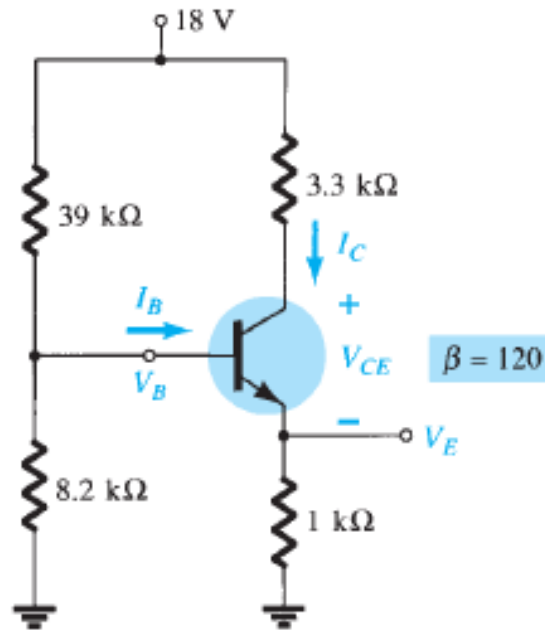

Fig. 4

Solution:

$$(a) R_{TH} = R_1 \parallel R_2 = 39k\Omega \parallel 39k\Omega = 6.78k\Omega$$

$$E_{TH} = \frac{R_C V_{CC}}{R_1 + R_2} = \frac{8.2k\Omega (18V)}{39k\Omega + 8.2k\Omega} = 3.13V$$

$$I_B = \frac{E_{TH} - V_{BE}}{R_{TH} + (\beta + 1)R_E} = \frac{3.13V - 0.7V}{6.78k\Omega + (121)(1k\Omega)} = 19.02\mu A$$

$$I_C = \beta I_B = 2.28mA$$

$$(b) V_{CE} = V_{CC} - I_C(R_C + R_E) = 18V - (2.28mA)(3.3k\Omega + 1k\Omega) = 8.2V$$

$$(c) I_B = \frac{I_C}{\beta} = 19.02\mu A$$

$$(d) V_E = I_E R_E \cong I_C R_E = (2.28mA)(1k\Omega) = 2.28V$$

$$(e) V_B = V_{BE} + V_E = 0.7V + 2.28V = 2.98V$$

Problem 5: For the voltage divider bias configuration of Fig. 5, determine:

(a) I_C , (b) V_E , (c) V_B , (d) R_1

Determine the saturation ($I_{C_{sat}}$) for the network of Fig. 5.

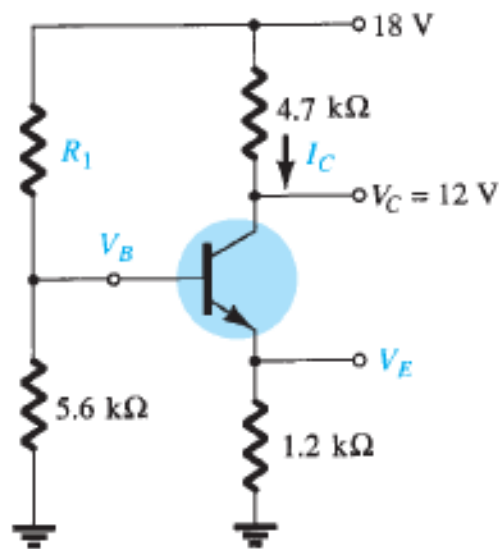

Fig. 5

Solution:

$$(a) I_C = \frac{V_{CC} - V_C}{R_C} = \frac{18\text{ V} - 12\text{ V}}{4.7\text{ k}\Omega} = 1.28\text{ mA}$$

$$(b) V_E = I_E R_E \cong I_C R_E = (1.28\text{ mA})(1.2\text{ k}\Omega) = 1.54\text{ V}$$

$$(c) V_B = V_{BE} + V_E = 0.7\text{ V} + 1.54\text{ V} = 2.24\text{ V}$$

$$(d) R_1 = \frac{V_{R_1}}{I_{R_1}}, \quad V_{R_1} = V_{CC} - V_B = 15.76\text{ V}$$

$$I_{R_1} \cong I_{R_2} = \frac{V_B}{R_2} = 0.4\text{ mA}$$

$$R_1 = \frac{V_{R_1}}{I_{R_1}} = \frac{15.76\text{ V}}{0.4\text{ mA}} = 39.4\text{ k}\Omega$$

$$I_{C_{sat}} = \frac{V_{CC}}{R_C + R_E} = \frac{18\text{ V}}{4.7\text{ k}\Omega + 1.2\text{ k}\Omega} = 3.49\text{ mA}$$

FET and MOSFET
Problems and Solutions

Problem 1. Given $I_{DSS} = 9 \text{ mA}$ and $V_P = -3.5 \text{ V}$, determine I_D when:

(a) $V_{GS} = 0 \text{ V}$, (b) $V_{GS} = -2 \text{ V}$, (c) $V_{GS} = -3.5 \text{ V}$, (d) $V_{GS} = -5 \text{ V}$.

Solution:

I_D is expressed as $I_D = I_{DSS} \left(1 - \frac{V_{GS}}{V_P} \right)^2$

(a) $V_{GS} = 0 \text{ V}$,

$$I_D = I_{DSS} \left(1 - \frac{V_{GS}}{V_P} \right)^2 = 9 \text{ mA} \left(1 - \frac{0 \text{ V}}{-4 \text{ V}} \right)^2 = 9 \text{ mA}$$

(b) $V_{GS} = -2 \text{ V}$,

$$I_D = I_{DSS} \left(1 - \frac{V_{GS}}{V_P} \right)^2 = 9 \text{ mA} \left(1 - \frac{-2 \text{ V}}{-3.5 \text{ V}} \right)^2 = 1.653 \text{ mA}$$

(c) $V_{GS} = -3.5 \text{ V}$,

$$I_D = I_{DSS} \left(1 - \frac{V_{GS}}{V_P} \right)^2 = 9 \text{ mA} \left(1 - \frac{-3.5 \text{ V}}{-3.5 \text{ V}} \right)^2 = 0 \text{ mA}$$

(d) $V_{GS} < V_P$, $I_D = 0 \text{ mA}$

Problem 2. Given $I_{DSS} = 6 \text{ mA}$ and $V_P = -4 \text{ V}$:

(a) Determine I_D at $V_{GS} = -2 \text{ V}$ and -3.6 V .

(b) Determine V_{GS} at $I_D = 3 \text{ mA}$ and 5.5 mA .

Solution:

$$(a) I_D = I_{DSS} \left(1 - \frac{V_{GS}}{V_P} \right)^2 = 6mA \left(1 - \frac{-2V}{-4.5V} \right)^2 = 1.852mA$$

$$I_D = I_{DSS} \left(1 - \frac{V_{GS}}{V_P} \right)^2 = 6mA \left(1 - \frac{-3.6V}{-4.5V} \right)^2 = 0.24mA$$

$$(b) V_{GS} = V_P \left(1 - \sqrt{\frac{I_D}{I_{DSS}}} \right)$$

$$V_{GS} = V_P \left(1 - \sqrt{\frac{I_D}{I_{DSS}}} \right) = (-4.5V) \left(1 - \sqrt{\frac{3mA}{6mA}} \right) = -1.1381V$$

$$V_{GS} = V_P \left(1 - \sqrt{\frac{I_D}{I_{DSS}}} \right) = (-4.5V) \left(1 - \sqrt{\frac{5.5mA}{6mA}} \right) = -0.192V$$

Problem 3. Given $I_D=14mA$ and $V_{GS}=1V$, determine V_P if $I_{DSS}=9.5mA$ for a depletion – type MOSFET.

Solution:

$$V_P = \frac{V_{GS}}{1 - \sqrt{\frac{I_D}{I_{DSS}}}} = \frac{+1V}{1 - \sqrt{\frac{14mA}{9.5mA}}} = \frac{1}{-0.21395} \cong -4.67V$$

4. Given $k = 0.4 \times 10^{-3} A/V^2$ and $I_{D(on)} = 3mA$ with $V_{GS(on)} = 4V$, determine V_T .

Solution:

For the enhancement-type MOSFET

$$I_D = k(V_{GS(on)} - V_T)^2$$

Now V_T is expressed as

$$(V_{GS(on)} - V_T)^2 = \frac{I_D}{k}$$

$$(V_{GS(on)} - V_T) = \sqrt{\frac{I_D}{k}}$$

$$V_T = V_{GS(on)} - \sqrt{\frac{I_D}{k}}$$

$$\begin{aligned} V_T = V_{GS(on)} - \sqrt{\frac{I_D}{k}} &= 4 \text{ V} - \sqrt{\frac{3 \text{ mA}}{0.4 \times 10^{-3}}} \\ &= 4 \text{ V} - \sqrt{7.5} \text{ V} \\ &= 1.261 \text{ V} \end{aligned}$$

Operational Amplifier

Problems and Solutions

Problem 1: What is the output voltage in the circuit of Fig. 1?

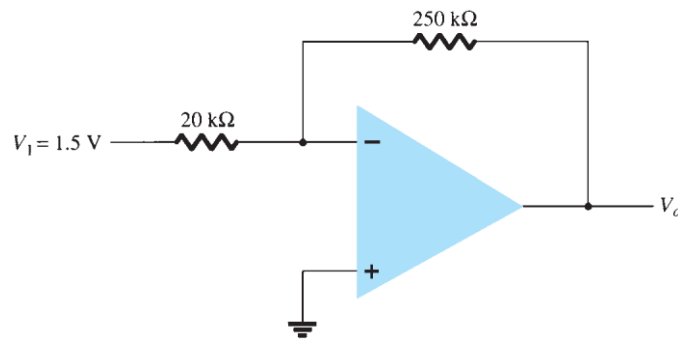

Fig. 1

Solution:

$$V_o = -\frac{R_f}{R_1} V_1 = -\frac{250k\Omega}{20k\Omega} (1.5 \text{ V}) = -18.75 \text{ V}$$

Problem 2: What output voltage results in the circuit of Fig. 2 for an input of $V_1 = -0.3 \text{ V}$?

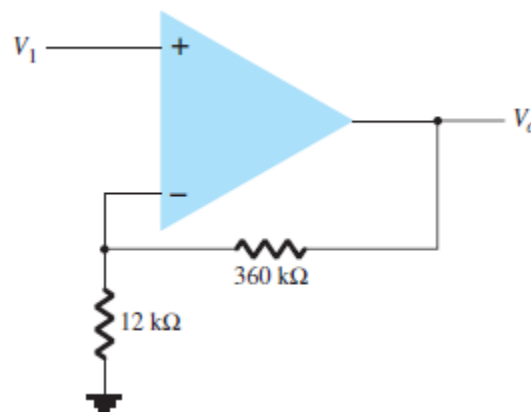

Fig. 2

Solution:

$$V_o = \left(1 + \frac{R_f}{R_1}\right) V_1 = \left(1 + \frac{360k\Omega}{12k\Omega}\right) (-0.3 \text{ V}) = -9.3 \text{ V}$$

Problem 3: What range of output voltage is developed in the circuit of Fig.3?

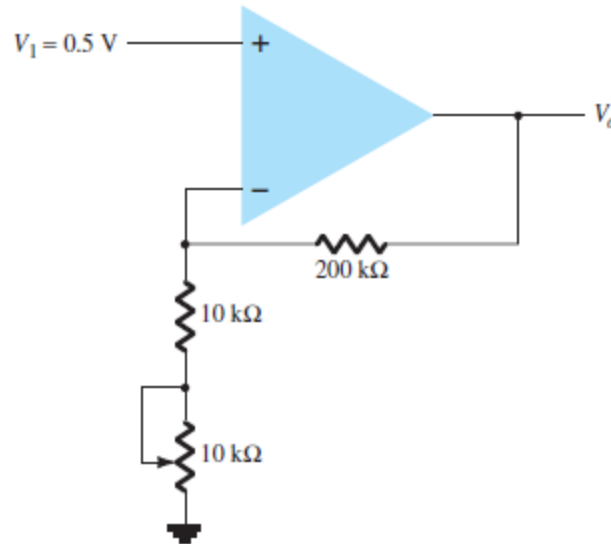

Fig. 3

Solution: The output voltage (V_0) equation for the Fig. 3 is

$$V_0 = \left(1 + \frac{R_f}{R_1} \right) V_1$$

For $R_1 = 10 \text{ k}\Omega$,

$$V_0 = \left(1 + \frac{R_f}{R_1} \right) V_1 = \left(1 + \frac{200 \text{ k}\Omega}{10 \text{ k}\Omega} \right) (0.5 \text{ V}) = 10.5 \text{ V}$$

For $R_1 = 20 \text{ k}\Omega$,

$$V_0 = \left(1 + \frac{R_f}{R_1} \right) V_1 = \left(1 + \frac{200 \text{ k}\Omega}{20 \text{ k}\Omega} \right) (0.5 \text{ V}) = 5.5 \text{ V}$$

So, the output voltage (V_0) varies from 5.5 V to 10.5 V.

Problem 4: Calculate the output voltage of the circuit in Fig. 4 for $R_f = 68 \text{ k}$.

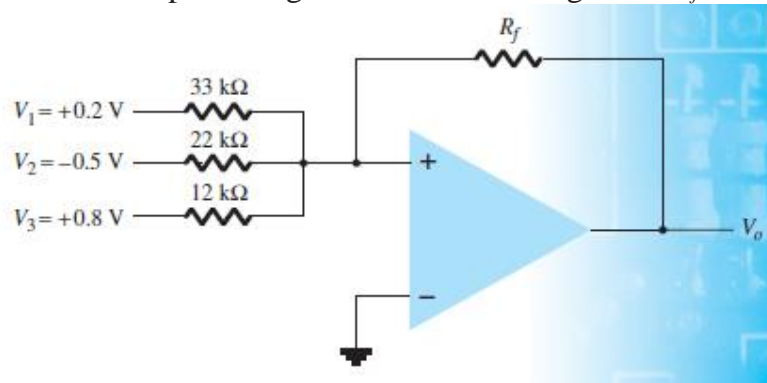

Fig. 4

Solution:

The output voltage for the Fig. 4 is expressed as

$$V_o = - \left[\frac{R_f}{R_1} V_1 + \frac{R_f}{R_2} V_2 + \frac{R_f}{R_3} V_3 \right]$$

$$V_o = - \left[\frac{68 \text{ k}\Omega}{33 \text{ k}\Omega} (0.2 \text{ V}) + \frac{68 \text{ k}\Omega}{22 \text{ k}\Omega} (-0.5 \text{ V}) + \frac{68 \text{ k}\Omega}{12 \text{ k}\Omega} (0.8 \text{ V}) \right] = -3.39 \text{ V}$$

Problem 5: Calculate the output voltage of the circuit in Fig. 5.

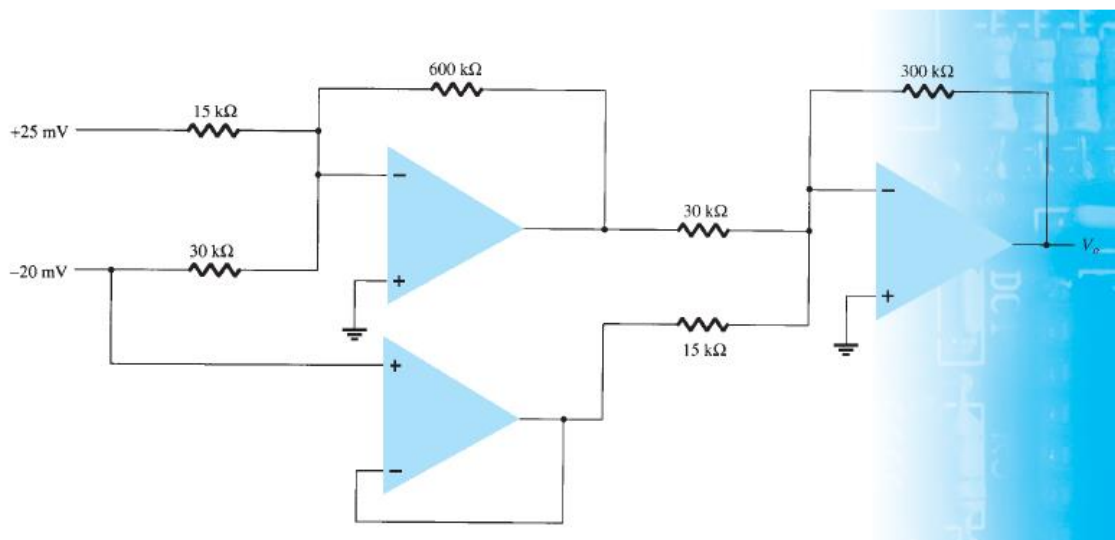

Fig. 5

Solution:

$$V_o = - \left[\left(\frac{600 \text{ k}\Omega}{15 \text{ k}\Omega} \right) (25 \text{ mV}) + \left(\frac{600 \text{ k}\Omega}{30 \text{ k}\Omega} \right) (-20 \text{ mV}) \right] \left(- \frac{300 \text{ k}\Omega}{30 \text{ k}\Omega} \right) + \left[- \left(- \frac{300 \text{ k}\Omega}{15 \text{ k}\Omega} \right) (-20 \text{ mV}) \right]$$

$$= 6.4 \text{ V}$$

Problem 6: Calculate the output voltage in the circuit of Fig. 6.

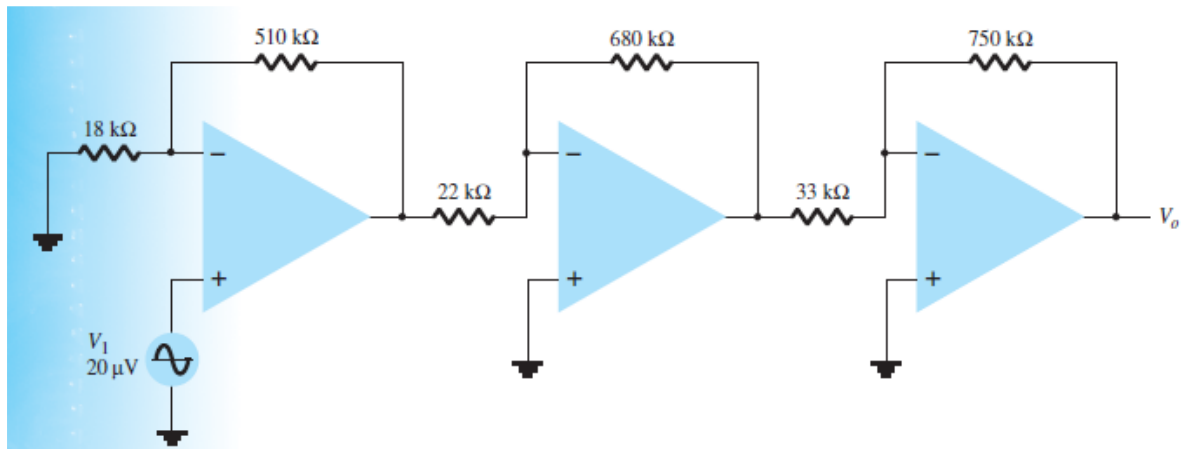

Fig. 6

Solution:

$$V_o = -1 \left(1 + \frac{510k\Omega}{18k\Omega} \right) (20\mu V) \left[-\frac{680k\Omega}{22k\Omega} \right] \left[-\frac{750k\Omega}{33k\Omega} \right]$$

$$= 412mV$$

Problem 7: For the circuit of Fig. 7, calculate I_L .

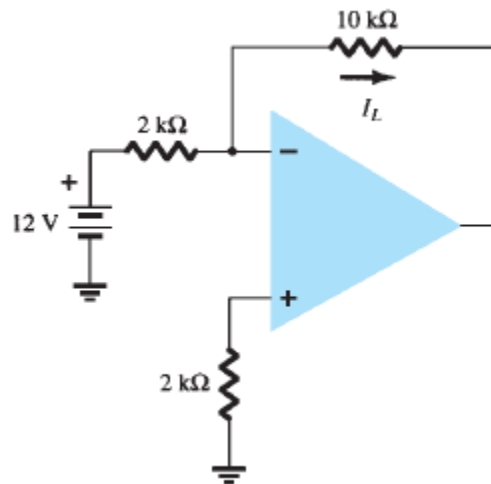

Fig. 7

Solution:

$$I_L = \frac{V_1}{R_1} = \frac{12V}{2k\Omega} = 6mA$$

Problem 8: Determine the output voltage for the circuit in Fig. 8.

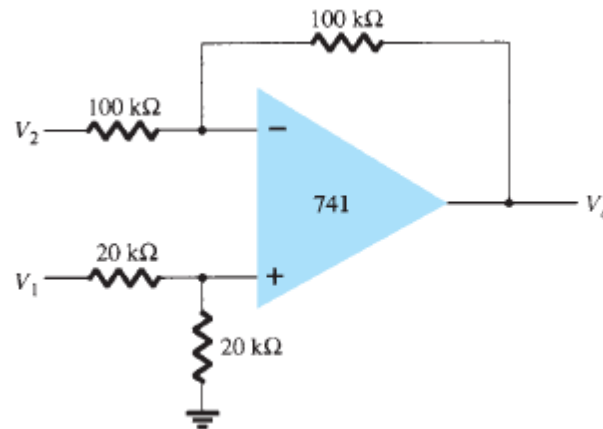

Fig. 8

Solution:

$$V_o = \left(\frac{20k\Omega}{20k\Omega + 20k\Omega} \right) \left(\frac{100k\Omega + 100k\Omega}{100k\Omega} \right) V_1 - \frac{100k\Omega}{100k\Omega} V_2$$

$$= V_1 - V_2$$

Problem 9: Calculate the CMRR (in dB) for the circuit measurements of $V_d = 1$ mV, $V_o = 120$ mV, $V_c = 1$ mV, and $V_o = 20$ mV.

Solution:

$$A_d = \frac{V_o}{V_d} = \frac{120mV}{1mV} = 120$$

$$A_c = \frac{V_o}{V_c} = \frac{20mV}{1mV} = 20 \times 10^{-3}$$

$$\text{Gain in dB} = 20 \log_{10} \frac{A_d}{A_c} = 20 \log_{10} \frac{120}{20 \times 10^{-3}}$$

$$= 75.56 \text{ dB}$$

Problem 10: Determine the output voltage of an op-amp for input voltages of $V_{i1} = 200 \text{ mV}$ and $V_{i2} = 140 \text{ mV}$. The amplifier has a differential gain of $A_d = 6000$ and the value of CMRR is: (a) 200, (b) 10^5 .

Solution:

$$V_d = V_{i1} - V_{i2} = 200 \mu\text{V} - 140 \mu\text{V} = 60 \mu\text{V}$$

$$V_c = \frac{V_{i1} + V_{i2}}{2} = \frac{(200 \mu\text{V} + 140 \mu\text{V})}{2} = 170 \mu\text{V}$$

$$(a) \text{ CMRR} = \frac{A_d}{A_c} = 200$$

$$A_c = \frac{A_d}{200} = \frac{6000}{200} = 30$$

$$(b) \text{ CMRR} = \frac{A_d}{A_c} = 10^5$$

$$A_c = \frac{A_d}{10^5} = \frac{6000}{10^5} = 0.06 = 60 \times 10^{-3}$$

Now V_0 is determined using the formula

$$V_0 = A_d V_d \left[1 + \frac{1}{\text{CMRR}} \frac{V_c}{V_d} \right]$$

$$(a) V_0 = 6000(60 \mu\text{V}) \left[1 + \frac{1}{200} \frac{170 \mu\text{V}}{60 \mu\text{V}} \right] = 365.1 \text{ mV}$$

$$(b) V_0 = 6000(60 \mu\text{V}) \left[1 + \frac{1}{10^5} \frac{170 \mu\text{V}}{60 \mu\text{V}} \right] = 360.01 \text{ mV}$$